

PL - SZAFKA 3D ANITA / SK - SKRIŇA 3D ANITA / HU - 3D ANITA SZEKRÉNY

! Pri montáži, je nevyhnutné dodržiavať montážny postup. Vynechanie alebo nedodržanie bodu montáže, môže viesť k nesprávnemu zmontovaniu. Nesprávne zmontovaný tovar, stráca záruku a je nebezpečný pre užívateľa. Poškodený alebo nekompletný tovar hláste infolinke.

! Az összeszerelés során pontosan követni kell az összeszerelési lépéseket. Egyes lépések kihagyása vagy egyes pontok be nem tartása helytelen összeszerelést eredményezhet. A helytelenül összeszerelt termékekre nem lesz érvényes a garancia, továbbá a felhasználóra is veszélyes lehet. Amennyiben sérült vagy hiányos terméket kapott, kérem azonnal jelezze felénk.

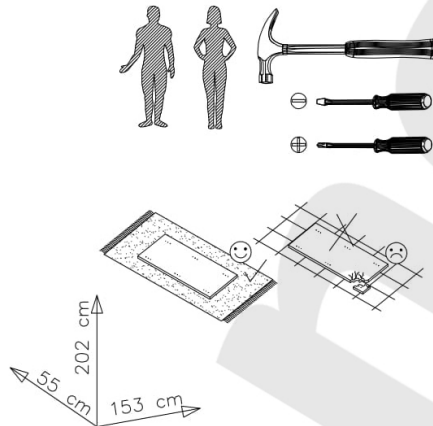

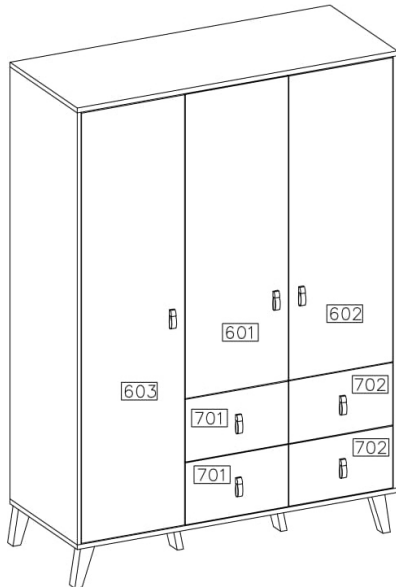

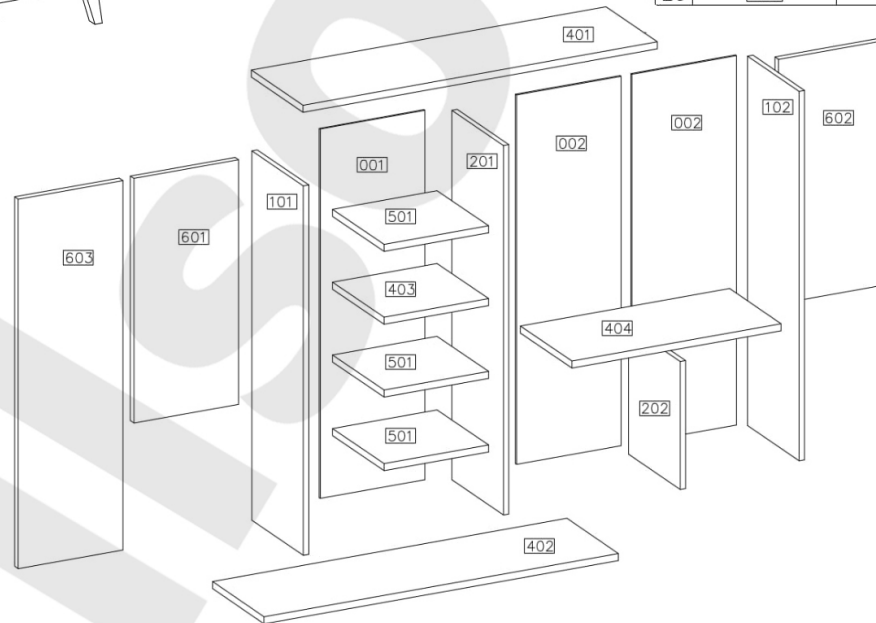
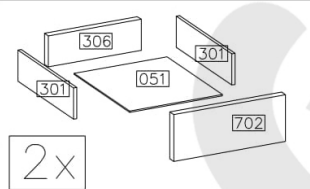
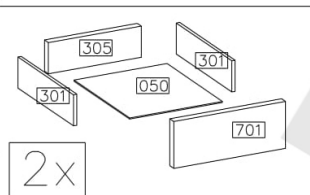

#	ART. NR	X
1	401	1
2	402	1
3	403	1
4	404	1
5	101	1
6	102	1
7	201	1
8	202	1
9	601	1
10	602	1
11	603	1
12	701	2
13	702	2
14	301	8
15	305	2
16	306	2
17	050	2
18	051	2
19	001	1
20	002	2



24	24	24	70	70	7	7	25	2	1	1
110	6	12	12	1	4	4SZT	9	6	3	12



1

	
12	8
	
6	1

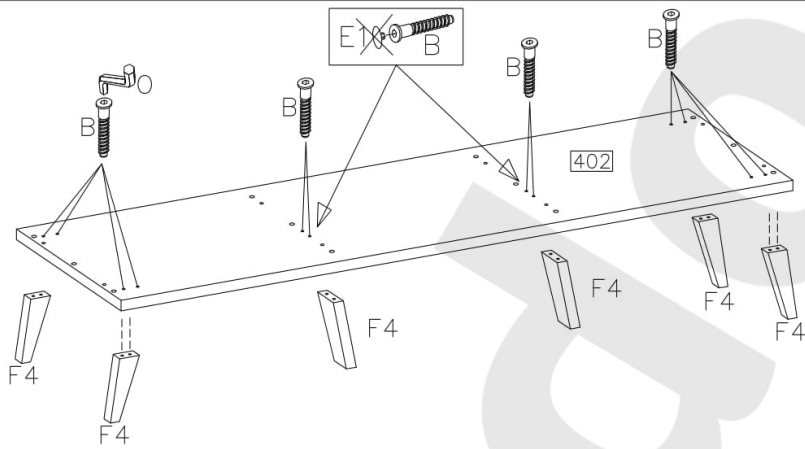



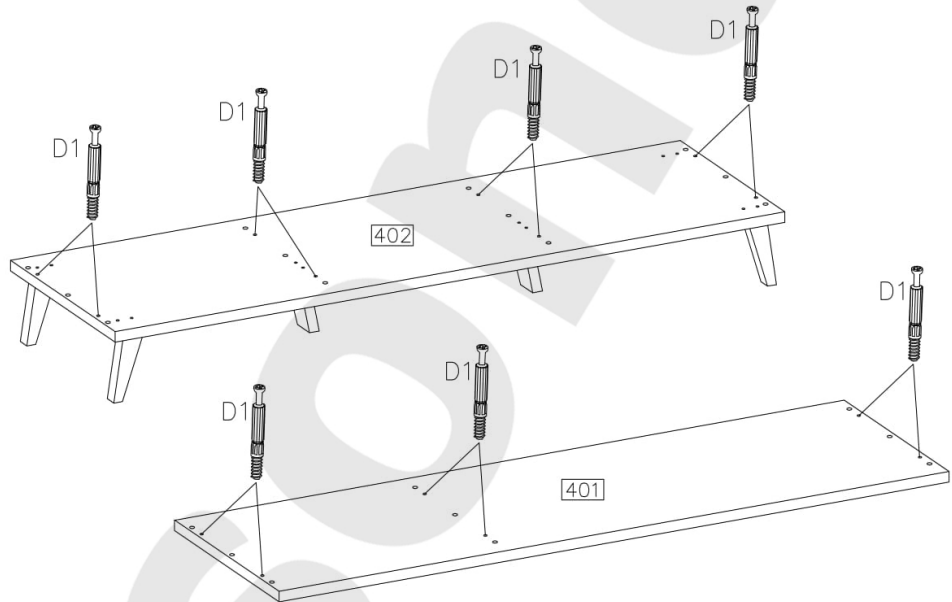

E1  B

2

14



3

				
18	12	2	4SZT	12

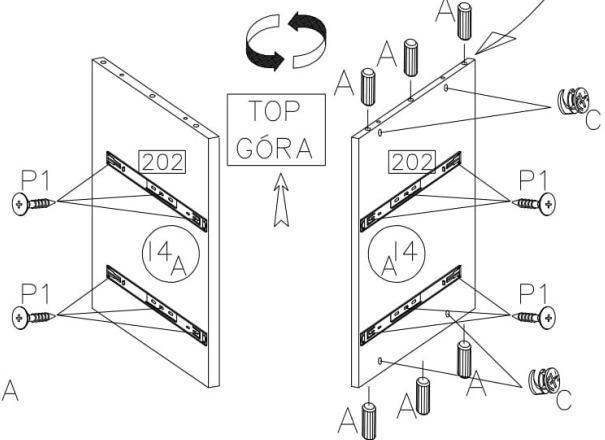
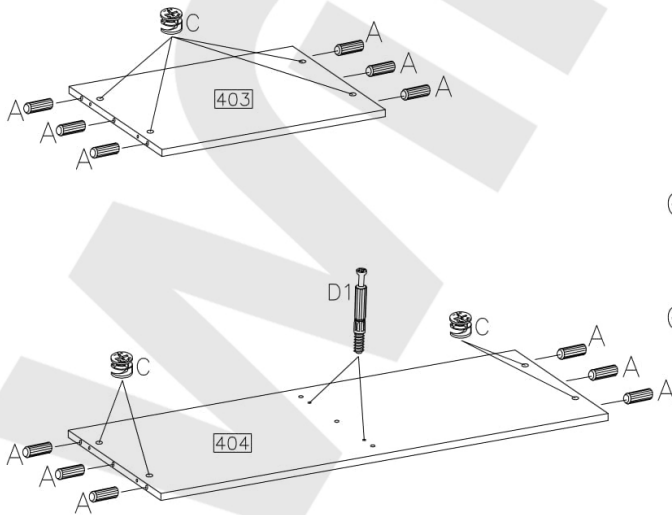
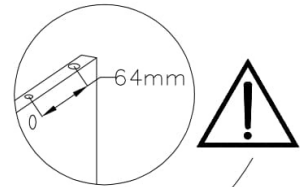
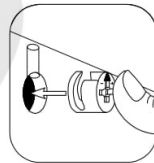

4

	2SZT	4
$\varnothing 8 \times 30 \text{mm}$	$\varnothing 15 / 12 \text{mm}$	$\varnothing 4.0 \times 16 \text{mm}$
12	8	8
6	6	1

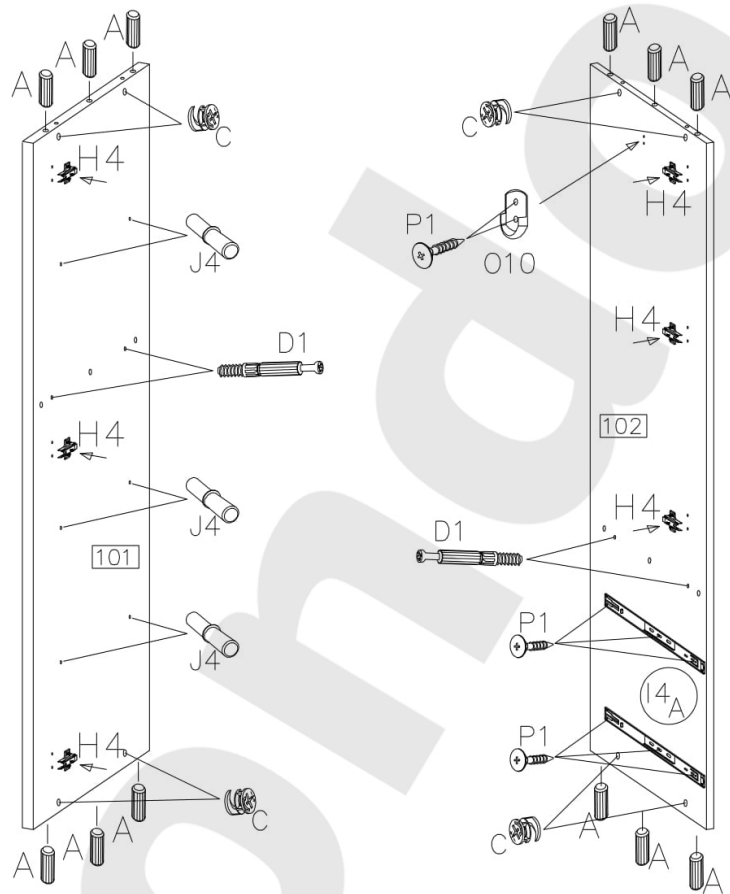
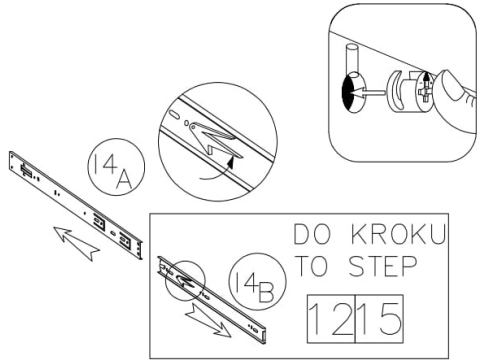

5

	2SZT	4
$\varnothing 8 \times 30 \text{mm}$	$\varnothing 15 / 12 \text{mm}$	$\varnothing 4.0 \times 16 \text{mm}$
6	4	8
6	1	

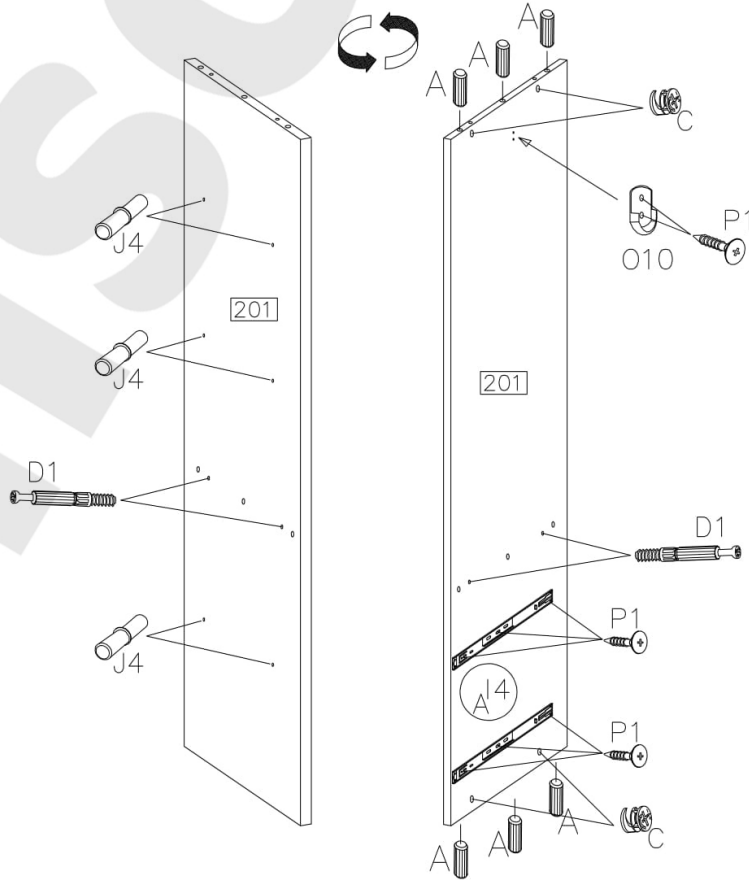
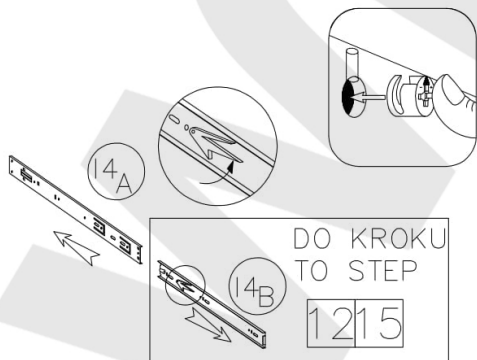

6

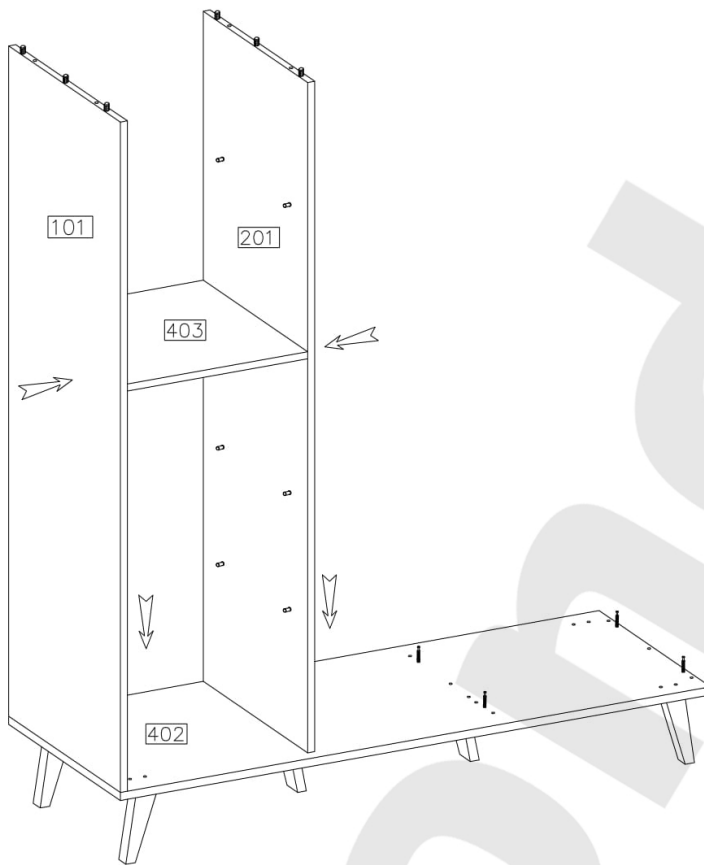
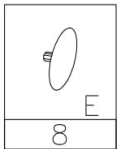

7

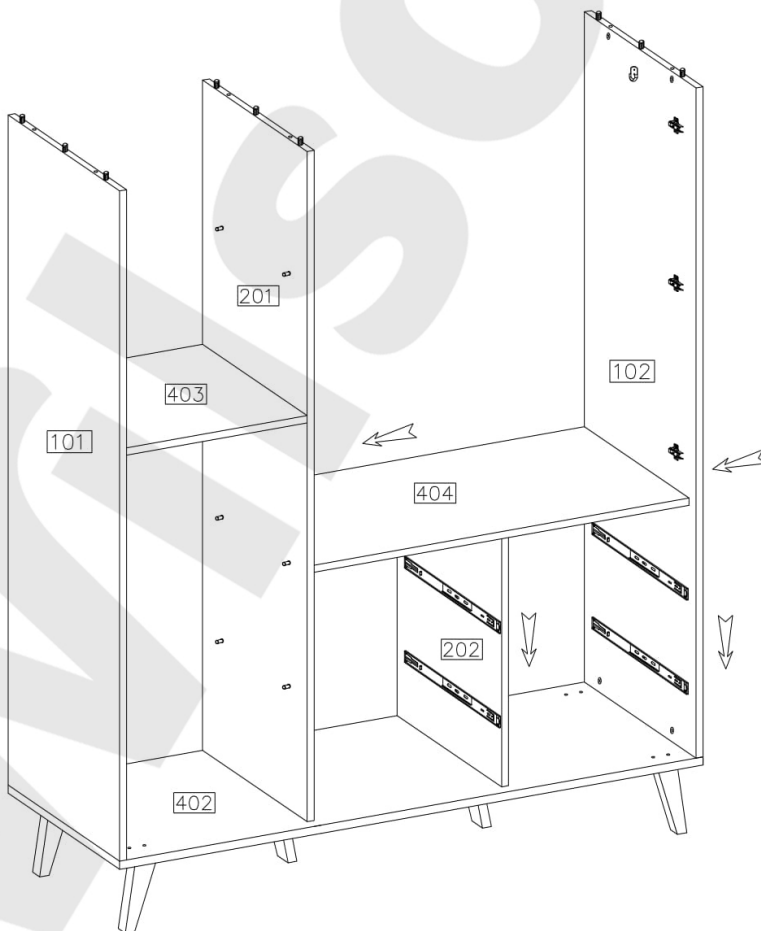
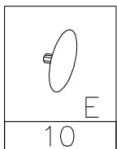

8

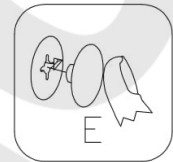
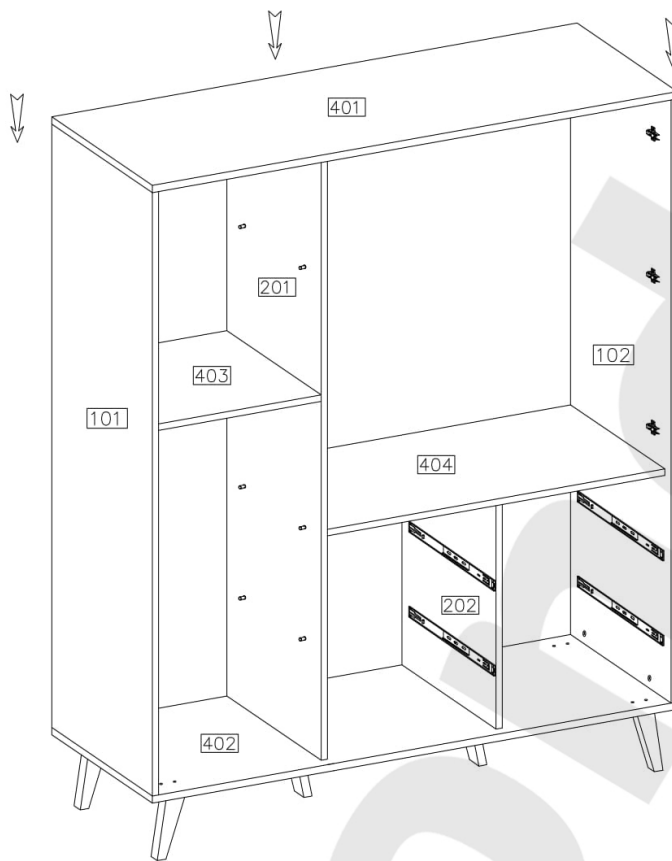
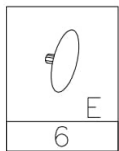

9

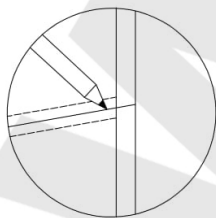
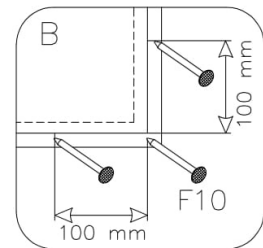
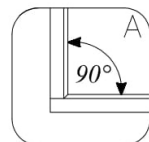
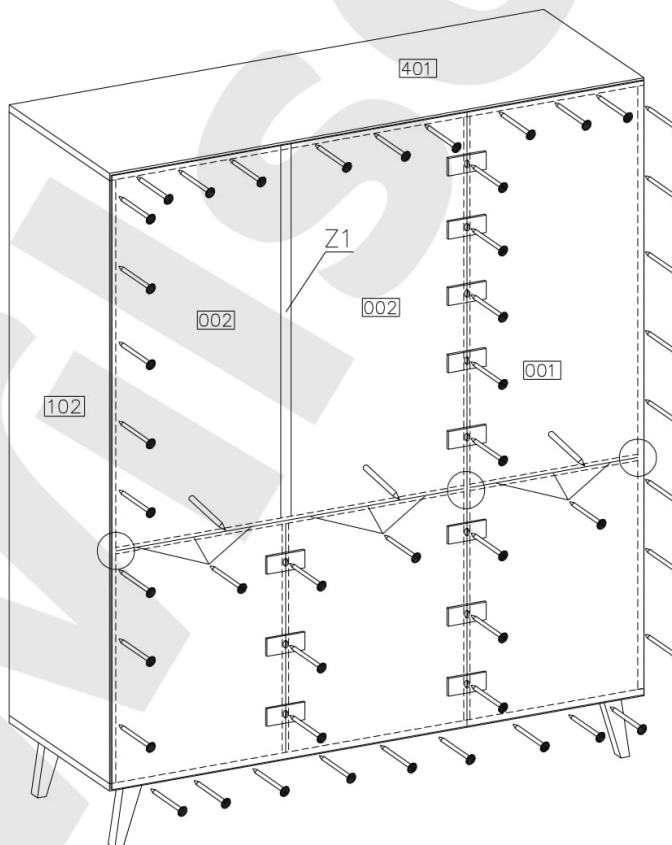
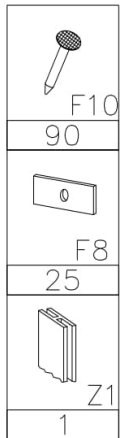

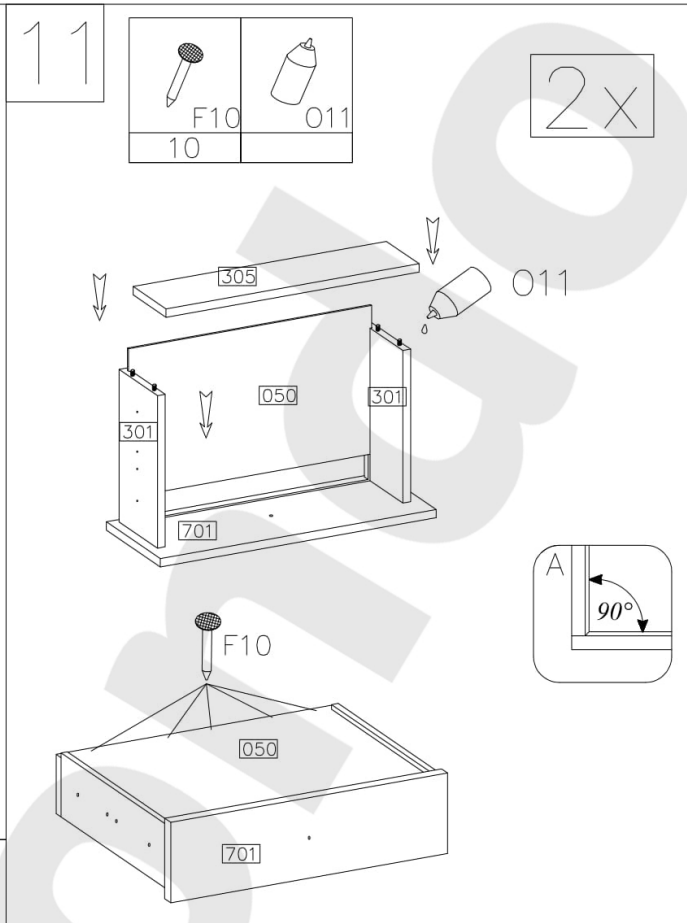
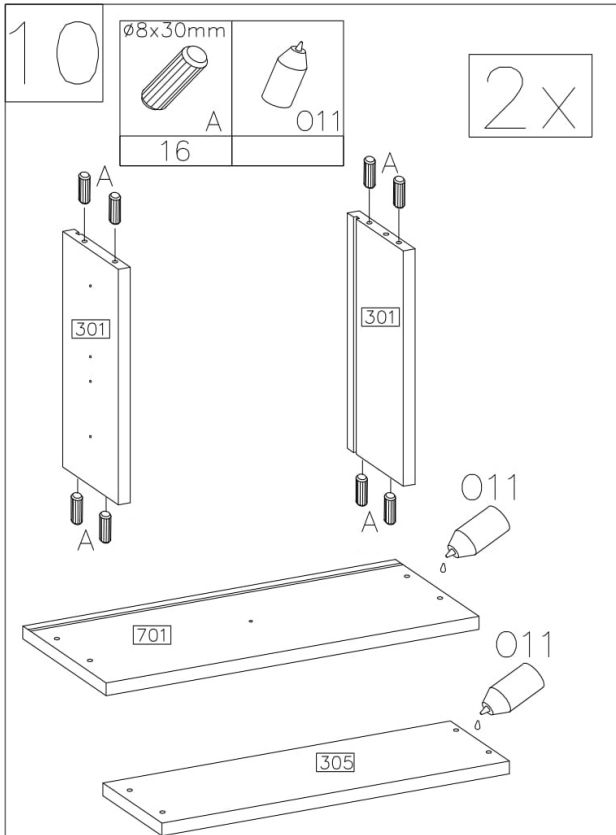

Diel 701 - 485/255/16 - ! diery na kolíky sú vzdialené od kraja 20 mm na oboch stranách !
Diel 305 - 454/180/16
Diel 050 - 435/375/3

701-es elem - 485/255/16 - ! a tiplik furatai 20 mm távolságra vannak az elem szélétől mindkét oldalon !
305-ös elem - 454/180/16
050-es elem- 435/375/3

Najprv vložte dno úložného priestoru, následne až primontujte zadnú časť.

Először a fiók alját helyezze be, csak ezt követően erősítse hozzá a fiók hátulját.

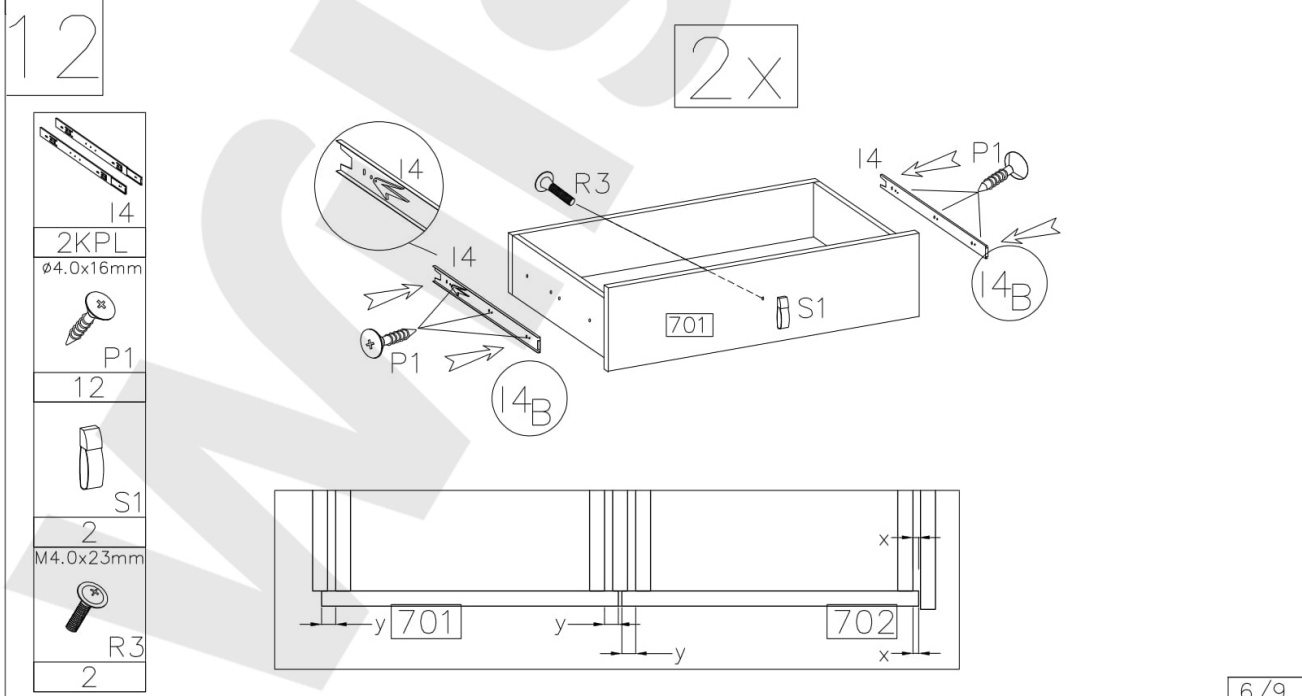

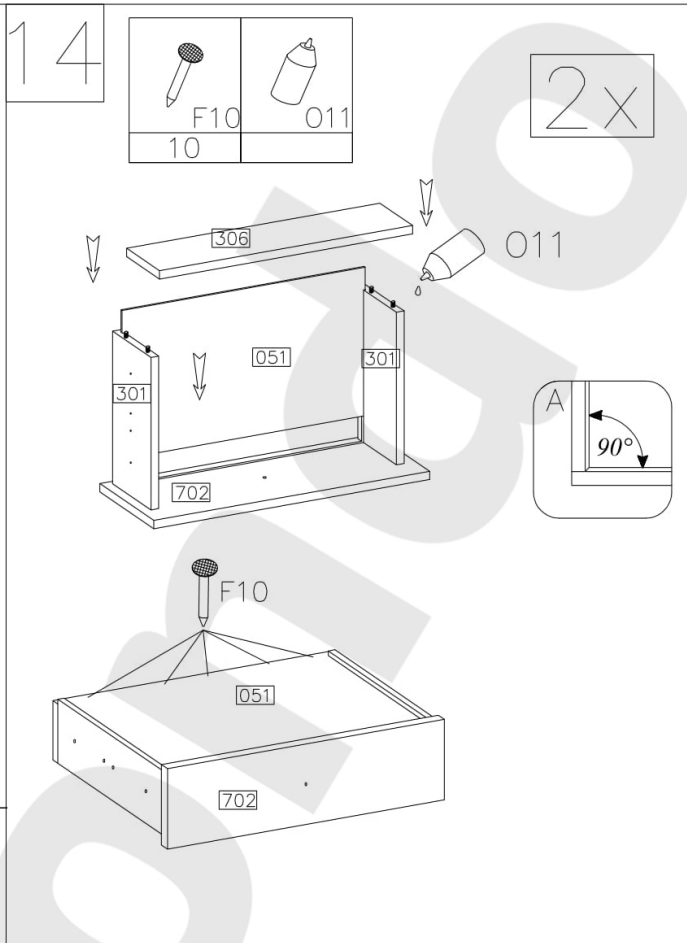
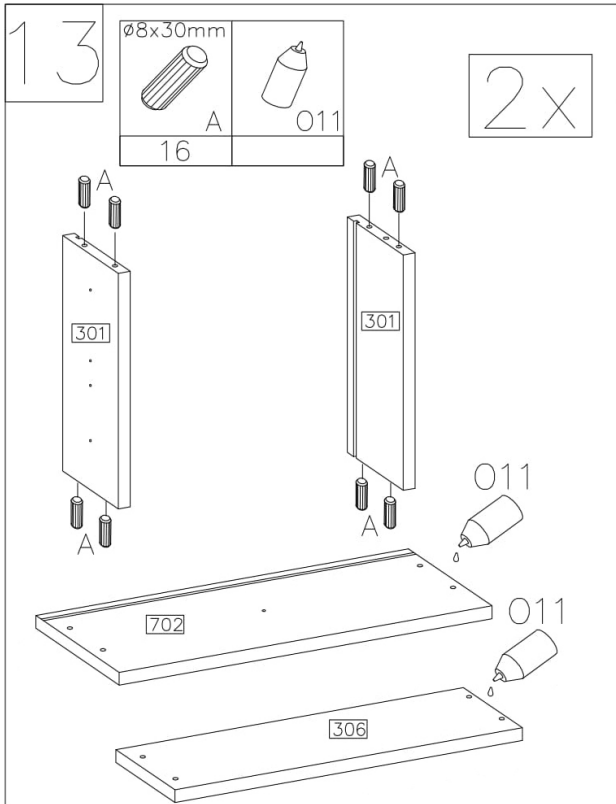

Diel 702 - 485/255/16 - ! diery na kolíky sú vzdialené od kraja 16 mm na ľavej strane a 20 mm na pravej strane !
Diel 306 - 461/180/16
Diel 051 - 442/375/3

702-es elem - 485/255/16 - ! a tiplik furatai 20 mm távolságra vannak az elem szélétől a jobb oldalon és 16 mm-re a bal oldalon !
306-os elem - 461/180/16
051-es elem - 442/375/3

Najprv vložte dno úložného priestoru, následne až primontujte zadnú časť.

Először a fiók alját helyezze be, csak ezt követően erősítse hozzá a fiók hátulját.

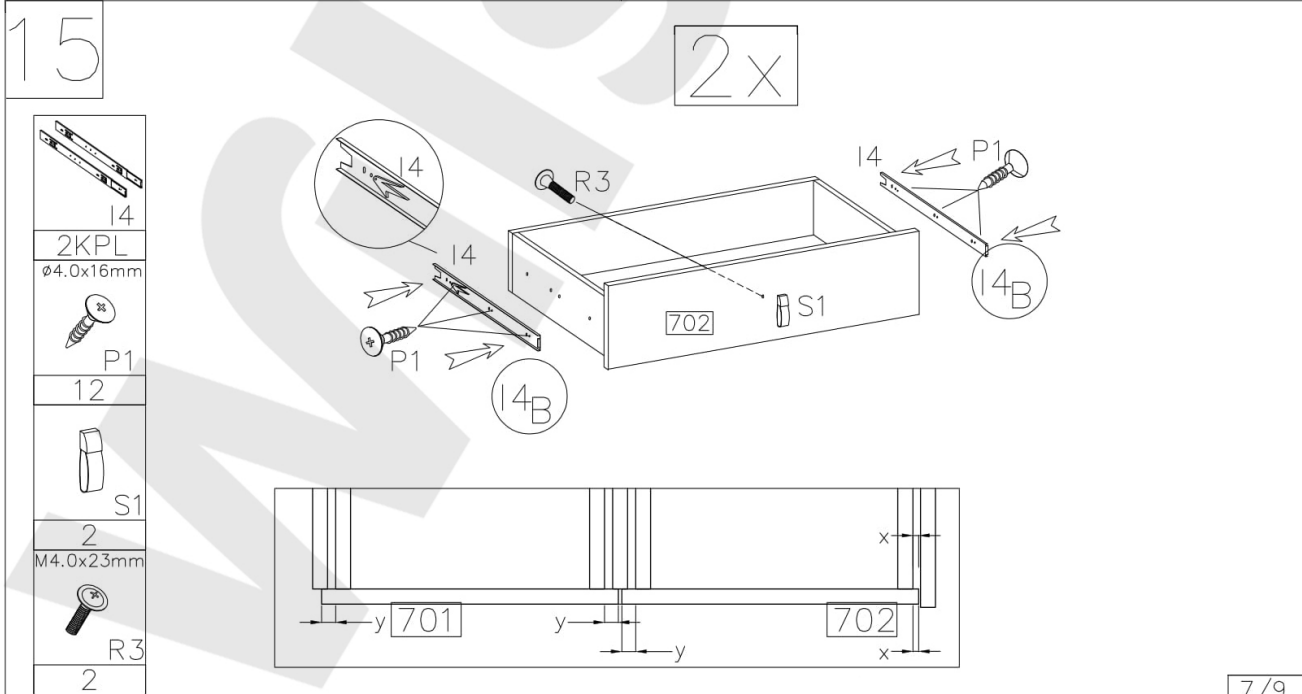

16

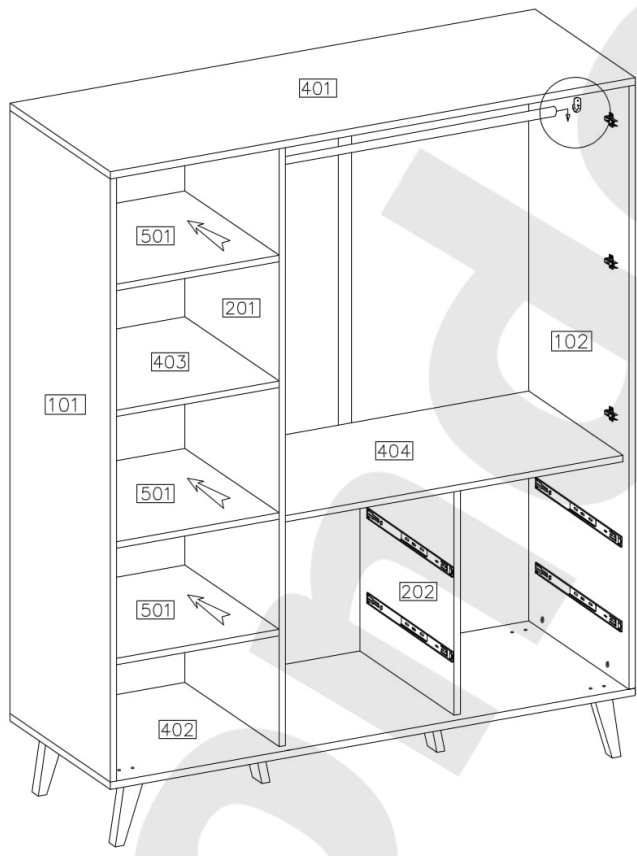
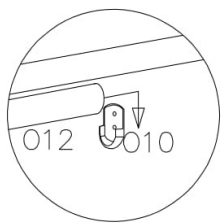
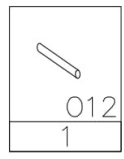

17

